

# Halsted Coffee Table

---

## ASSEMBLY INSTRUCTIONS





# JOON LOLOI

## ASSEMBLY INSTRUCTIONS: BEFORE BEGINNING

Read these instructions carefully and keep for future reference. Refer to parts inventory for guidance, and ensure you have all pieces before starting. When assembling, place all parts on a soft, clean, and flat surface such as a carpet to prevent scratches.

1. Carefully unpack and position the item on a clean, non-marring surface to assemble.
2. Read these Assembly Instructions from beginning to end before starting to assemble.
3. Take an inventory of the required parts to ensure all are available.
4. To prevent accidental choking hazards, keep all packing materials away from small children.
5. Only tighten hardware until ALL hardware are fully engaged on their locations. Over tighten bolts will damage the bolt threads.
6. Use only factory provided hardware to assemble. Unapproved hardware can damage product or jeopardize the structural integrity of the product.
7. The use of power tool to assemble is not recommended due to high risk of over-torque, which can damage the product.

PARTS INVENTORY		
ID	DESCRIPTION	QTY
1	TABLE TOP	1
2	TABLE LEGS	2
3	SUPPORT TIE BAR	2

HARDWARE INVENTORY				
ID	IMAGE	DESCRIPTION	SIZE	QTY
A		ALLEN BOLT	M6 x 20mm	16
B		ALLEN BOLT	M6 x 45mm	4
C		FLAT WASHER	06 x 017mm	20
D		LOCK WASHER	06 x 013mm	20
E		ALLEN WRENCH/KEY	4mm	1

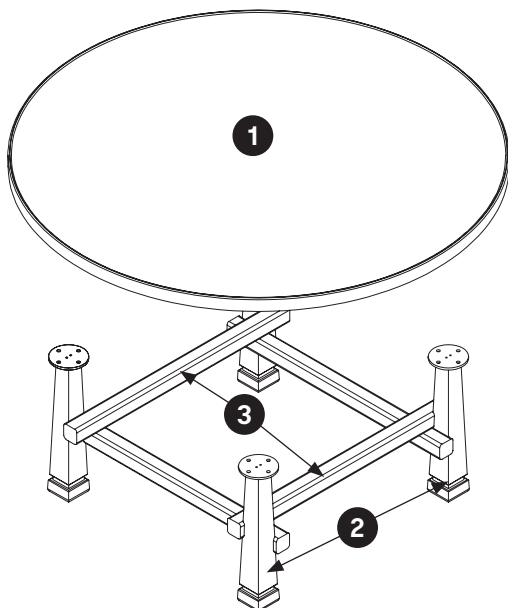

# JOON LOLOI

## STEP 1

Place the **TABLE TOP (1)** face down so the underside is easily accessible. Slide the **LOCK WASHER (D)** and **FLAT WASHER (C)** onto the **ALLEN BOLT (A)**. Align the bolt holes on the leg with those on the tabletop, then use the **ALLEN WRENCH (E)** to insert and tighten the **ALLEN BOLT (A)**. Repeat this step for all remaining bolt holes

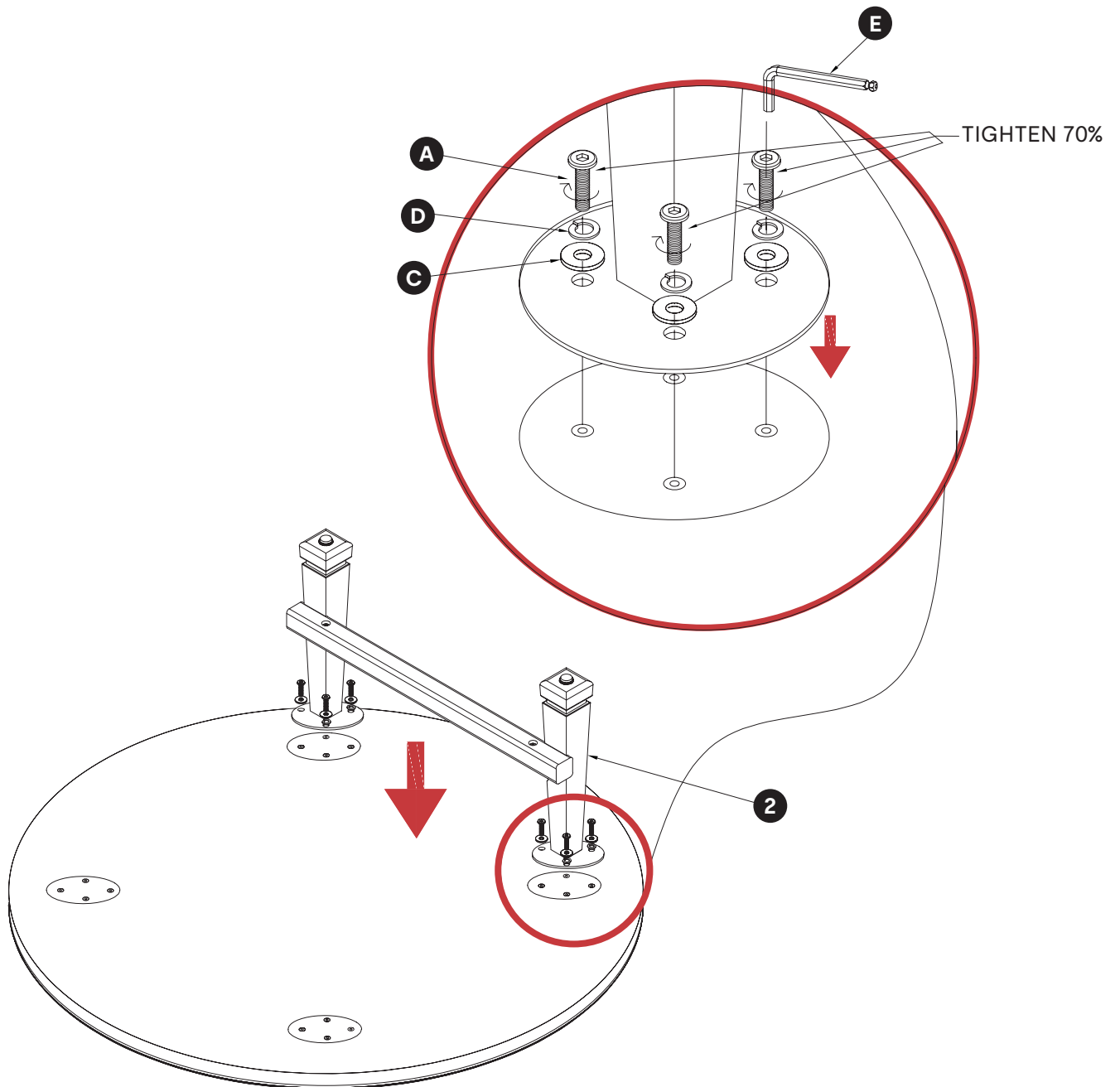

# JOON LOLOI

## STEP 2

Repeat **STEP 1** to attach the remaining legs.

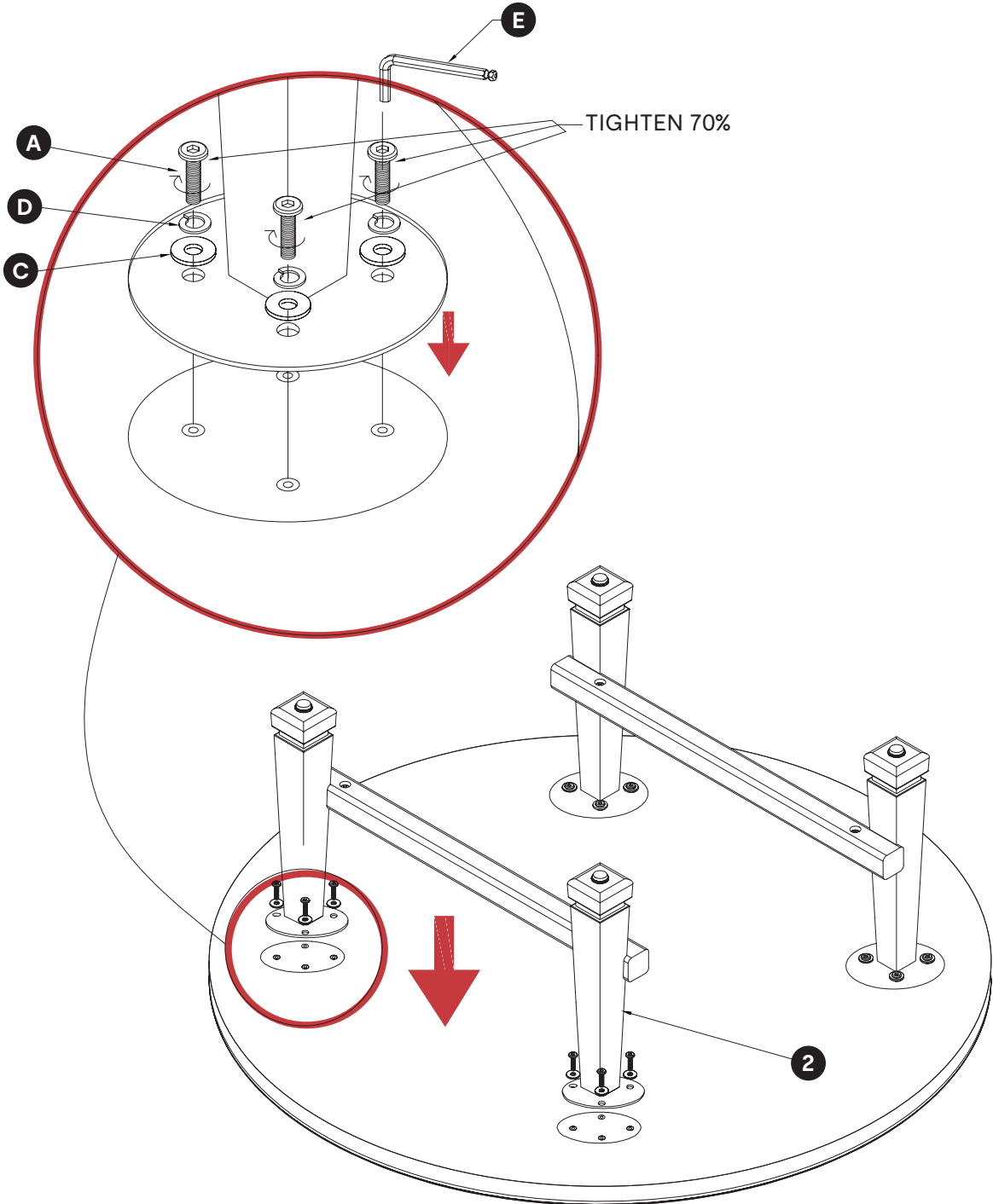

# JOON LOLOI

## STEP 3

Next, attach the two **SUPPORTS TIE BARS (3)**. Slide the **LOCK WASHER (D)** then a **FLAT WASHER (C)** onto the **ALLEN BOLT (B)**. Align the bolt holes on the legs with the holes on the **SUPPORT TIE BARS (3)**, then use the **ALLEN WRENCH (E)** to insert and tighten the **ALLEN BOLT (B)**. Repeat this step for the remaining bolt holes.

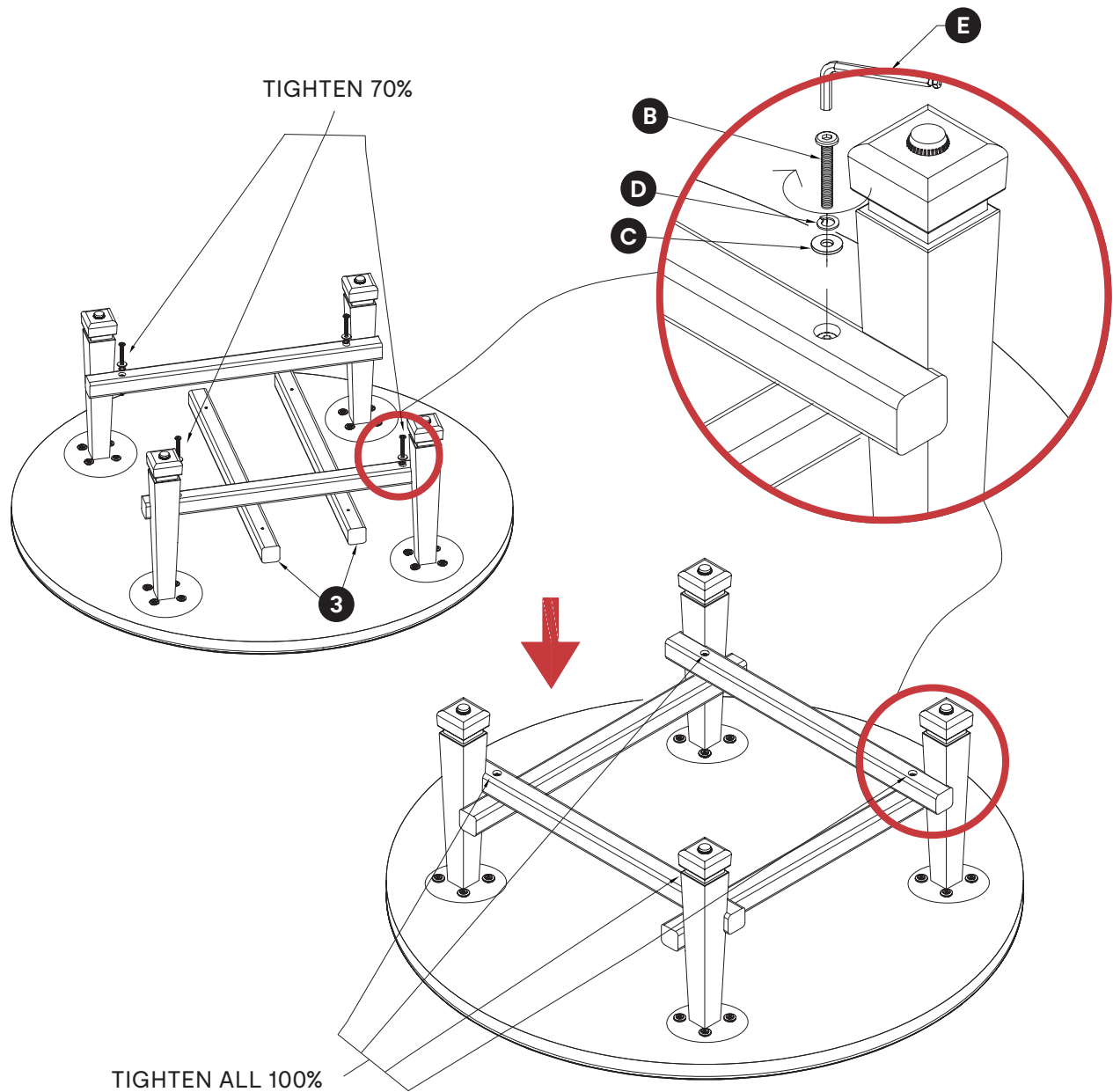

# JOON LOLOI

---

## STEP 4

Turn the Halsted Coffee Table upright after tightening all bolts. Once all components are securely in place, adjust the levelers as needed. Assembly is now complete.

